



FAN COVER FOR ELECTRIC MOTORS

IEC/MEC 80 T

MATERIALS

- DC04** Raw sheet metal
- DX54** Hot-dip galvanised sheet

FINISHING

- Zinc-plating
- Painting (RAL9005)
- [Other colours are available on request]
- Phosphodegreasing

RENDER



IEC/MEC 80 T

TECHNICAL DRAWING

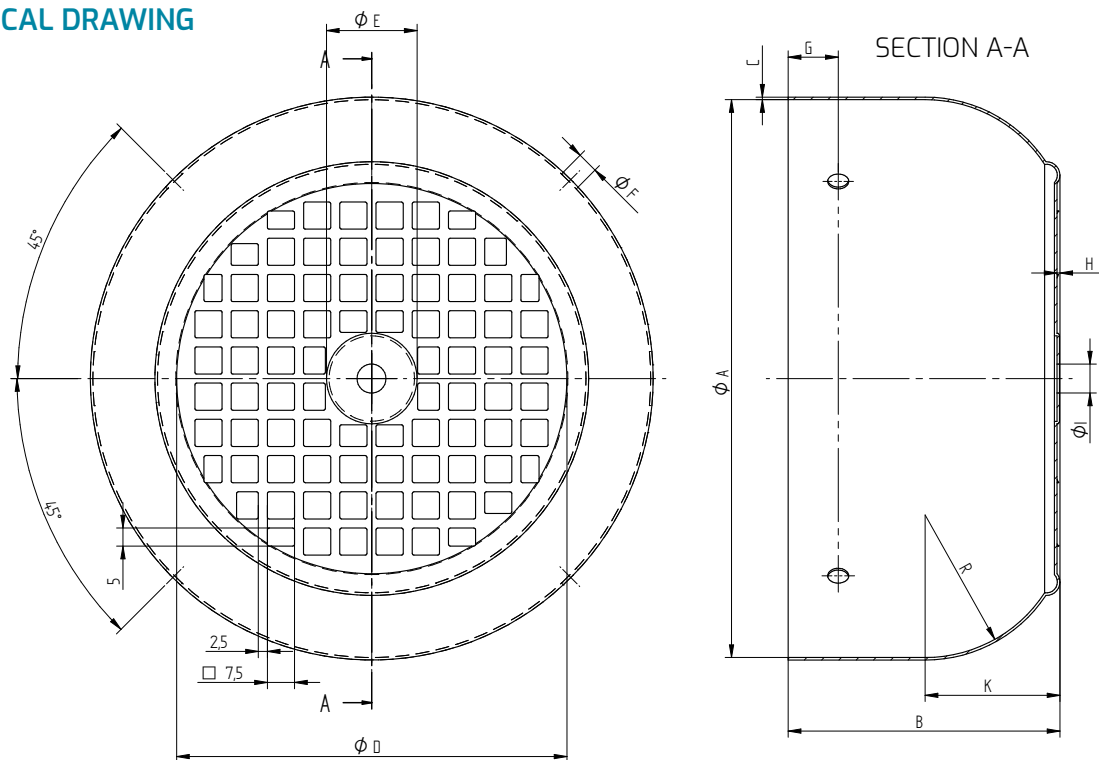

TECHNICAL DATA

Code	Dimension Description	Type T
A	∅	154
C	Steel Thickness	0,7
D	∅ Grill	108
E	Central Blanking	25
F	∅ Fixing Holes	5,8
R	Curvature Radius	40
H	Lowering Grill Height	1,5
K	Central Radius Height	39,5
cm ²	Air Flow Section	44,4
B	Height	75
G	Hole's Distance	13,8
I	Central Hole	8

Customizable on request

PACKING

Single Packing Dimensions	mm	790 x 580 x 308 h
Pieces for box	n.	115
Box weight	kg	27,4

