



FAN COVER FOR ELECTRIC MOTORS

IEC/MEC 56 T

MATERIALS

- DC04** Raw sheet metal
- DX54** Hot-dip galvanised sheet

FINISHING

- Zinc-plating
- Painting (RAL9005)
[Other colours are available on request]
- Phosphodegreasing

RENDER



IEC/MEC 56 T

TECHNICAL DRAWING

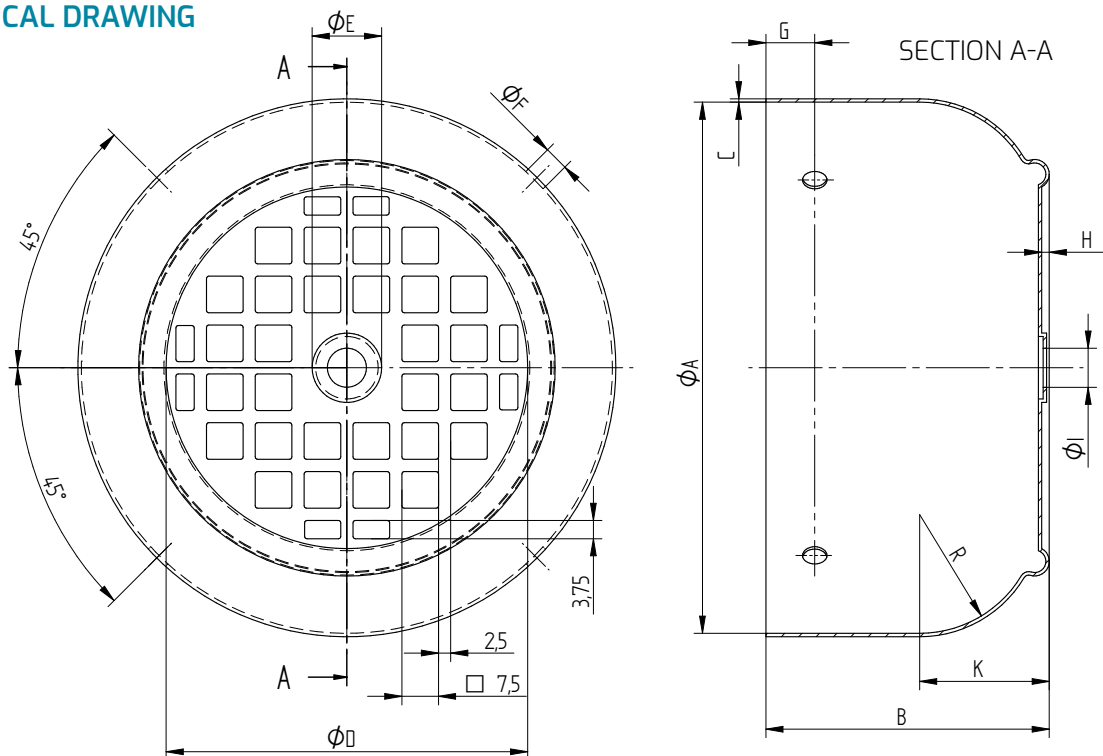

TECHNICAL DATA

Code	Dimension Description	Type T
A	Ø	108,5
C	Steel Thickness	0,7
D	Ø Grill	78
E	Central Blanking	14
F	Ø Fixing Holes	4,8
R	Curvature Radius	28
H	Lowering Grill Height	1,5
K	Central Radius Height	29
cm ²	Air Flow Section	18,5
B	Height	53,5
G	Hole's Distance	10,2
I	Central Hole	8

Customizable on request

PACKING

Single Packing Dimensions	mm	790 x 580 x 308 h
Pieces for box	n.	360
Box weight	kg	40,2

