



FAN COVER FOR ELECTRIC MOTORS

IEC/MEC 100 T/EXTENDED

MATERIALS

- DC04** Raw sheet metal
- DX54** Hot-dip galvanised sheet

FINISHING

- Zinc-plating
- Painting (RAL9005)
[Other colours are available on request]
- Phosphodegreasing

RENDER



IEC/MEC 100 T/EXTENDED

TECHNICAL DRAWING

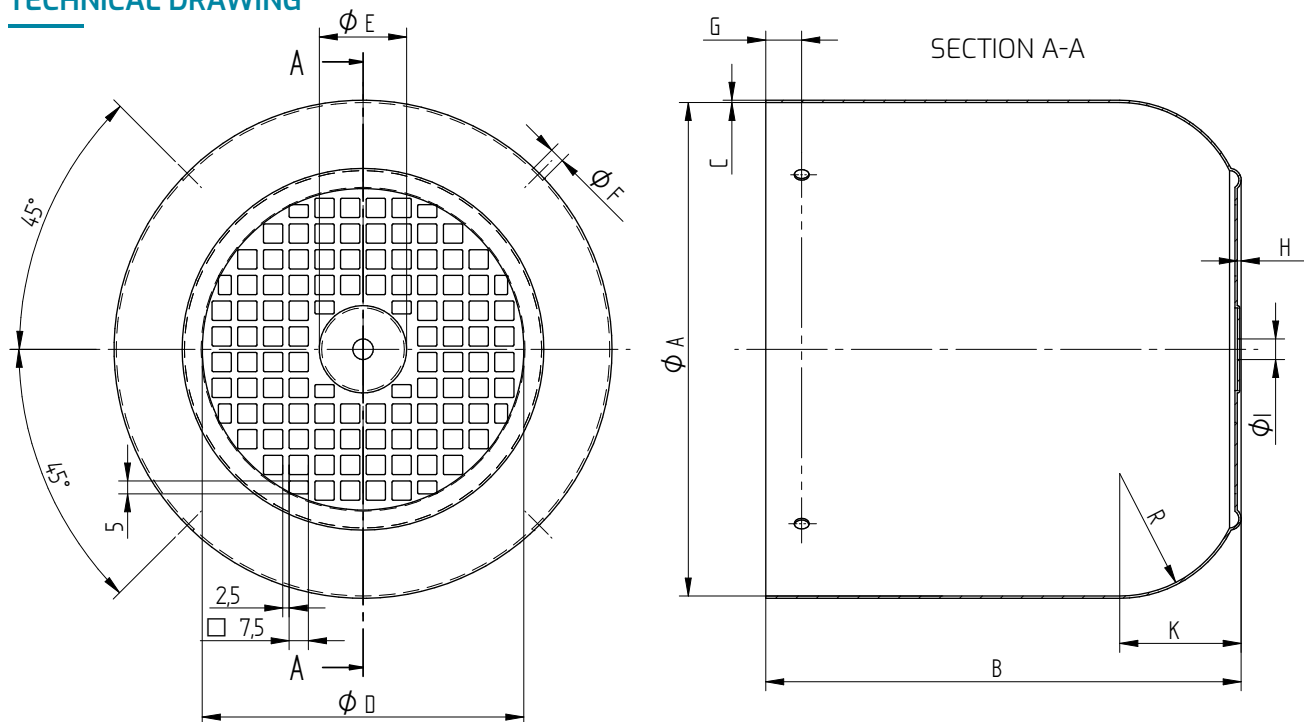

TECHNICAL DATA

Code	Dimension Description	Type T/EXTENDED
A	∅	192
B	Height	185
C	Steel Thickness	1
D	∅ Grill	133
E	Central Blanking	34
F	∅ Fixing Holes	5,8
G	Hole's Distance	<i>on customer request</i>
H	Lowering Grill Height	1,5
R	Curvature Radius	47,7
cm ²	Air Flow Section	58,6
I	Central Hole	8

Customizable on request

PACKING

Single Packing Dimensions	mm	790 x 580 x 308 h
Pieces for box *	n.	12
Box weight **	kg	-

* version h. 185 cm

** It depends on the required height



L.E.B. S.p.A. | Via Antonio Pacinotti 34 – 36040 Brendola (VI)
Tel. 0444 400668 – Fax 0444 400829
infoleb@leb.it | www.leb.it

REV. 09/21