



ELECTROPNEUMATIC HORN

LINE PN STORM 12V

E3 28 **E3** 10

Technical drawing

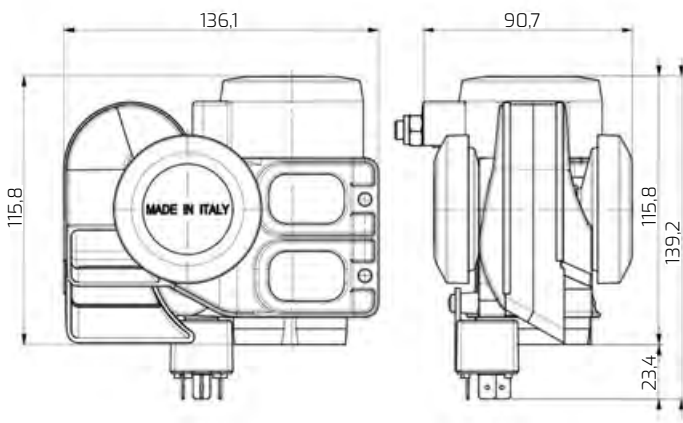

Connection

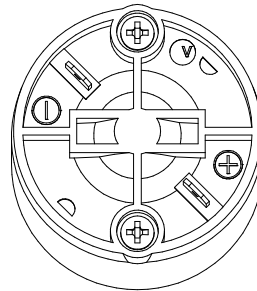

LINE PN STORM 12V

Technical features

Nominal Voltage	Vcc	12
Voltage Range	Vcc	11,4÷13,8
Current Consumption	A	<17
Sound Pressure Level (at 2 meters)	dB(A)	115
Frequency (High + Low Tone)	Hz	670 + 530
Terminals (No. 2 Faston 6,3 x 0,8mm)	nr	2
Durability (1" On + 4" Off)	cycles	>50.000
Corrosion resistance (UNI 9227)	h	>192
Operating and Storage Temperature	°C	from -30 to +80
Electrical Insulation (at 1000Vcc)	MΩ	>10
Vibrations (30 min x 3 axis)	g	3
Weight including bracket	gr	730

Packing

Single Packing Dimensions	mm	120 x 95 x 140 h
Master Carton Quantity	pcs	18
Master Carton Dimensions	cm	29 x 38 x 31 h
Master Carton Weight	kg	14,5

Mounting Instructions

TWISTER and STORM - ELECTROPNEUMATIC HORN

The compressor and the horns must be fixed to a flat, rigid surface (possibly metal) using the special brackets and screws supplied.

The horn must be installed in a position protected from:

- prays of water generated by the movement of the vehicle or by washing systems.
- foreign bodies such as stones, insects, mud, snow, etc.
- excessive heat sources (above 80°) such as radiators, exhaust pipes, engines.

ATTENTION!

It is recommended to install the horn with the electrical connection of the compressor pointing downwards.

