



ELECTROMAGNETIC HORN BEEPER | $\varnothing 90$

LINE INOXSEA H 24V

E3 28

Technical drawing

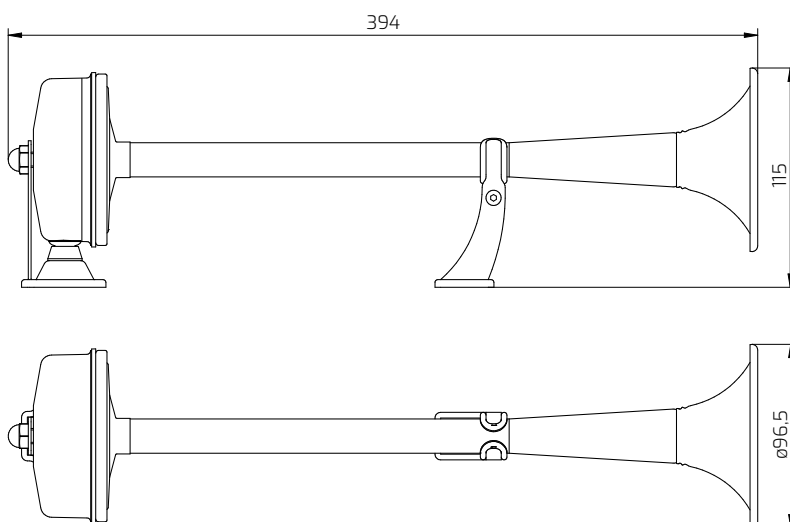

Connection

2 Electrical wires

LINE INOXSEA H 24V

Technical features

Nominal Voltage	Vcc	24
Voltage Range	Vcc	22,8÷27,6
Current Consumption	A	<3
Sound Pressure Level (at 2 meters)	dB(A)	110
Frequency (High Tone)	Hz	375
Terminals (No. 2 Faston 6,3 x 0,8mm)	nr	2
Durability (1" On + 4" Off)	cycles	>50.000
Corrosion resistance (UNI 9227)	h	>192
Operating and Storage Temperature	°C	from -30 to +80
Electrical Insulation (at 1000Vcc)	MΩ	>10
Vibrations (30 min x 3 axis)	g	3
Weight including bracket and screws	gr	900

Packing

Single Packing Dimensions	mm	515 x 130 x 110 h
Master Carton Quantity	pcs	16
Master Carton Dimensions	cm	53 x 47 x 50 h
Master Carton Weight	kg	16,5

Mounting Instructions

C91 - C91/LUX - INOXSEA horn (connections with electric wires)

The horn must be fixed to a flat, rigid (possibly metallic) surface using the special bracket and screws supplied.

The horn must be installed in a position protected from:

- sprays of water generated by the movement of the vehicle or by washing systems.
- foreign bodies such as stones, insects, mud, snow, etc.
- excessive heat sources (above 80°).

ATTENTION!

It is recommended to install the horn with the mouths slightly downwards in order to avoid the entry of foreign bodies (water, mud, insects, etc.). In the case of horizontal mounting of the horn, it is recommended to mount a special SPOILER.

